

12 ——— **Liberator Convertible Hand Trucks** ———

600 lb. Capacity Hand Truck

1200 lb. Capacity Platform Truck

Choose one of these popular models or build your own from components on page 13



“Senior”

Model A13-B81-C6-D5

- Loop Handle with Comfort Sleeve
- Heavy-Duty Frame with 5 Crossmembers
- 18” x 9” Solid Extruded Aluminum Nose Plate
- High Quality 10” x 3.5” 4 Ply Pneumatic Tires with Precision Bearings
- Crossbar with Comfort Sleeve



“Junior”

Model B70-C6-D5

- Double Grip Swing Arm
- Heavy-Duty Frame with 4 Crossmembers
- 18” x 9” Solid Extruded Aluminum Nose Plate
- High Quality 10” x 3.5” 4 Ply Pneumatic Tires with Precision Bearings



Guaranteed to be the best convertible you’ve ever used or send it back

Liberator Convertible Features:

- Thicker and stronger frame with heavy duty side channel reinforcements.
- Crossbars are four-sided tube with two sides ribbed for added strength.
- Crossbars are attached with individual aircraft-grade rivets at each corner providing better frame integrity.
- Heavy duty high tensile steel axle will not bow under maximum loads.
- Balloon cushion caster wheels provide better rollability (wing brake standard on one wheel).
- Our components can be used to upgrade other leading brands of hand trucks.

Two year warranty!!

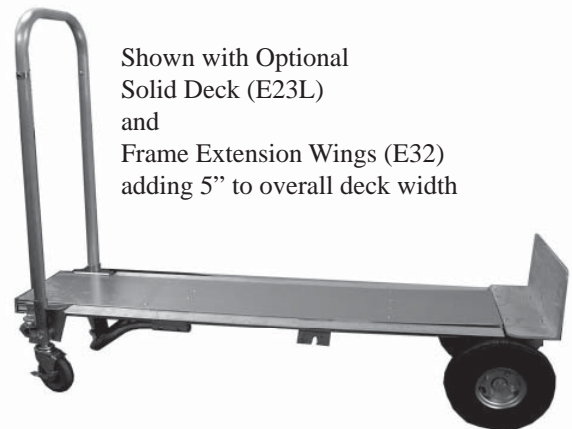

Shown with Optional Solid Deck (E23L) and Frame Extension Wings (E32) adding 5” to overall deck width

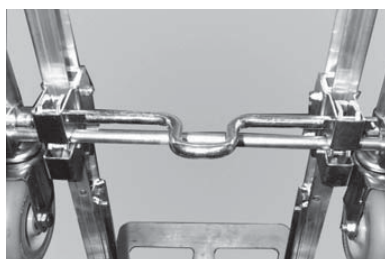

- One piece solid release bar
- Simple design with minimal moving parts for maximum reliability
- Smoothest release action in the industry

SPECIFICATIONS	SR	JR
Overall width	20”	20”
Frame width	12”	12”
Overall length (platform mode)	56”	43”
Height as hand truck	61.5”	52”
Height as platform truck	46”	41”
Platform bed length	51.5”	38.25”
Platform height from floor	11”	11”
Balloon cushion swivel casters	5”x1.25”	5”x1.25”

Liberator Convertible Components and Replacement Parts

A Handles

B Frames

For Senior Models Only



A1
Standard Loop



A13
Standard Loop
w/ Comfort Sleeve



A26
Double Grip
w/ U Brace



B70
Jr. Double Grip



B75
Jr. Double Grip
2 Crossbars



B80
Standard



B81
High Capacity

C Noses

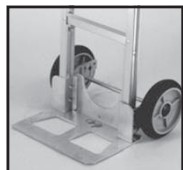

C1, C19
14" x 7.5"
Recessed Heel
C1 w/ Cutouts
C19 w/o Cutouts
Extruded Aluminum



CA1
14" x 7.5"
Cast, Recessed Heel
w/ Cutouts
500 lb. Capacity

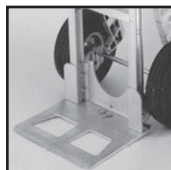

C7
14" x 10.5"
Recessed Heel
w/ Cutouts
Extruded Aluminum



CA3
14" x 12"
Cast, Recessed Heel
w/ Cutouts
500 lb. Capacity



C2, C20
18" x 7.5"
Recessed Heel
C2 w/ cutouts
C20 w/o cutouts
Extruded Aluminum

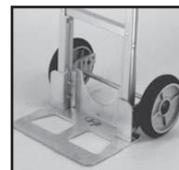

CA2
18" x 7.5"
Cast, Recessed heel
w/ cutouts
500 lb. Capacity

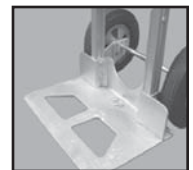

C15
18" x 10.5"
Recessed Heel
w/ Cutouts
Extruded Aluminum



C16, C12
14" x 7.5"
Front Mount
Extruded Aluminum
C16- w/o Cutouts
C12- w/ Cutouts



C4
14" x 9"
Front Mount
Extruded Aluminum



C8
16" x 12"
Front Mount
Extruded Aluminum

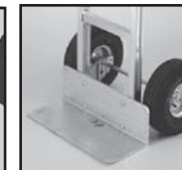

C17, C13
18" x 7.5"
Front Mount
Extruded Aluminum
C17- w/o Cutouts
C13- w/ Cutouts

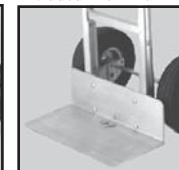

C6, C26
18" x 9"
Front Mount
Extruded Aluminum
C6- w/o Cutouts
C26- w/Cutouts



C14
18" x 12"
Front Mount
Extruded Aluminum

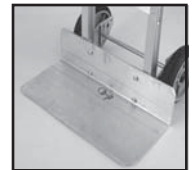

C10
20" x 9"
Front Mount
Extruded Aluminum



C9
20" x 12"
Front Mount
Extruded Aluminum

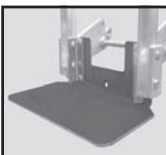

C28, C29
C28 18" x 9"
C29 14" x 9"
Rear Mount
Steel

(C28 & C29 standard as rear mount, can be front mounted upon request)

D Wheels



D10
10" x 2 1/8"
Balloon Cushion
Polyolefin Hub
600 lb. Capacity



D6
10" x 3"
Carefree
Solid Foam
600 lb. Capacity



D5
10" x 3.5"
4 Ply Pneumatic
2 pc. Steel Hub
600 lb. Capacity



D2
10" x 2.5"
Semi-pneumatic
1 pc. Plastic Hub
500 lb Capacity

E Accessories

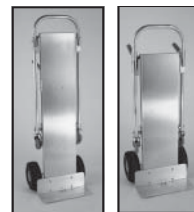

Solid Decks
Removable Snap-On
or Permanent

E23L SR Snap On
E25L SR Permanent

E22L JR Snap On
E24L JR Permanent

E49 SR 18" Wide Permanent Deck



Folding Nose Extensions

Tubular
E2F, E5R 36"
E6F, E6R 30"

Full Channel Extruded
E2F, E2R 20"
E3F, E3R 30"

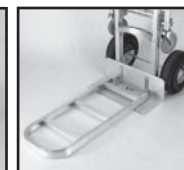

E32 Fixed Wings
(Senior Only)

F-for use with Front Mount Nose Plates
R-for use with Recessed Heel and Rear Mount Nose Plates

S-SERIES DIRECT REPLACEMENT HAND TRUCKS

500 lb Capacity - Two Year Warranty



S-500

- Loop handle
- Straight frame with standard crossmembers
- 14" x 7.5" cast noseplate, recessed heel with cutouts
- 8" balloon cushion wheels with precision bearings



S-502

- Loop handle
- Straight frame with standard crossmembers
- 14" x 7.5" cast noseplate, recessed heel with cutouts
- 10" balloon cushion wheels with precision bearings



S-503

- Double grip handle
- Straight frame with standard crossmembers
- 18" x 7.5" extruded aluminum, solid front mount noseplate
- 10" x 3.5" 4 ply pneumatic wheels with precision bearings

500 lb. Capacity Hand Truck
1,000 lb. Capacity Platform Truck
Two Year Warranty

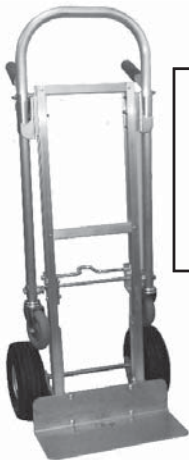

SJR

- Convertible Junior
- 18" x 7.5" extruded aluminum, solid front mount noseplate
- 10" x 3.5" 4 ply pneumatic wheels with precision bearings



SSR

- Convertible Senior
- 18" x 7.5" extruded aluminum, solid front mount noseplate
- 10" x 3.5" 4 ply pneumatic wheels with precision bearings



Direct Replacement Series Components	
<u>HANDLES</u>	
A1	Single Loop
A11	Double Grip
<u>FRAMES</u>	
B10	Straight Back, No Logo Crossmember
B75	Junior Frame, Double Grip No Logo Crossmember
B80	Senior Frame, Standard No Logo Crossmember
<u>NOSE PLATES</u>	
CA1	14" x 7.5" Cast, Recessed Heel
C17	18" x 7.5" Extruded Aluminum
<u>WHEELS</u>	
D5	10" x 3.5" Pneumatic, 4 Ply, Precision Bearings
D10	10" Balloon Cushion, Poly Core
D11	8" Balloon Cushion, Poly Core

Add Optional Stairclimbers



EIL Extruded Aluminum



EIC Cast Aluminum

14" Wide and 18 lbs!

- Specially designed brackets move each wheel in 1.5" - only 14" wide with D11 wheels
- Fits all standard Liberator hand trucks, including curved back frames, front mount noses, cast noses, C28 & C29 rear mount steel noses, and all handles.
- Fits all 8" & 10" wheels, including short axle wheels (see below).
- Parts are interchangeable with most competitors.
- Optional stairclimbers are engineered from steel for long life (also available in extruded aluminum)
- Coke OFS compatible!
- Ideal for beverage distributors, provisions companies, liquor distributors- anyone delivering in tight areas.



A12-B10-CA1-D12-NA
-NA Indicates Narrow Aisle



C23 Coke OFS
Compatible



-E40 Steel Stairclimber
for Narrow Aisle Hand Truck



-E44 Extruded Aluminum
Stairclimber for Narrow Aisle
Hand Truck



<u>Part Description</u>	<u>Part #</u>
(NA Indicates Narrow Aisle Component)	
LH Wheel Bracket NA	7507-001
RH Wheel Bracket NA	7507-002
Long Axle, Narrow Aisle	2002-272
Short Axle, Narrow Aisle	2002-273
Stairclimber (Pair), Narrow Aisle Steel	2002-E40
Stairclimber, Extruded Aluminum, Narrow Aisle	2002-E44
Completion Pack, Long Axle NA	2002-333
Completion Pack, Short Axle NA	2002-334

Developed for the Snack Food Delivery Professional

- Reduce your number of trips
- Lightweight aluminum construction - reduce fatigue
- Modular design allows perfect fit for individual drivers
- Extra long skids allow truck to slide easily out of the delivery vehicle
- Optional Folding nose for bulky packages (44" shown)
- Two Year Warranty



Shown with optional 51" skids

A8-B8-CA1-D11-E19-E4R

(Height with A8 Handle As Shown 75 1/2")

If adding skids order

- E19 for use with 8" wheels
- E20 for use with 10" wheels



Tubular Folding Nose Extension

36" **E5F/E5R**

44" **E4F/E4R**

F for use with Front Mount Nose

R for use with Rear Mount or Recessed Nose

110 lb. Capacity



Most popular models and handle styles are shown here, but our modular design allows your choice of any B&P handles, noseplates or wheels

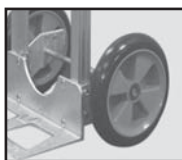

D10

10" x 2 1/8"
Balloon Cushion
Polyolefin Hub
600 lb. Capacity

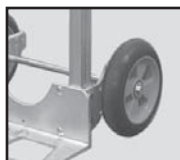

D11

8" x 2 1/8"
Balloon Cushion
Polyolefin Hub
600 lb. Capacity



D5

10" x 3.5"
4 Ply Pneumatic
2 pc. Steel Hub
600 lb. Capacity



D6

Carefree
10" x 3"
No Flat
Solid Foam
600 lb. Capacity



D14

Carefree
8" x 3"
No Flat
Solid Foam
600 lb. Capacity



D1

8" x 2"
High Performance
Dark Gray
Non-Marking
600 lb. Capacity



D9

8" x 2.5"
Pneumatic
2 pc. Steel Hub
500 lb. Capacity

HTA-10 Folding Snack Truck



- Lightweight, high capacity design
- 66" bed length allows you to carry large boxes of chips, pretzels, etc.
- 36" folding nose keeps boxes in place, yet folds up for transportation and storage
- Latches keep both the handle and folding nose in the upright position Standard with 14" x 7 1/2" cast noseplate (CA1) and 8" balloon cushion wheels (D11)
- 5" x 1 1/4" swivel stem casters provide a smooth ride and long life

SPECIFICATIONS

Overall Height	73"
Width (at nose plate CA1)	14"
Bed Length	66"
Handle Height	38"
Folding Nose Length	36"
Folding Nose Height	46"
Weight (w/ D11)	35 lb
Capacity (folding nose)	80 lb
Capacity (4 wheel)	200 lb

Noseplate Options

14" x 7 1/2" Cast/Recessed Heel Nose Standard	CA1
18" x 7 1/2" Cast/Recessed Heel	CA2
14" x 12" Cast/Recessed Heel	CA3
14" x 7 1/2" Extruded Aluminum/Recessed Heel	C1
18" x 7 1/2" Extruded Aluminum/Recessed Heel	C2

Wheel Options

8" Balloon Cushion Standard	D11
8" Aluminum Core Mold on Rubber	D12
8" Pneumatic	D9

9" Apron



11 deg. bend

APRON HAND TRUCK DOCKBOARDS

- A lightweight solution for dock to truck/truck to truck applications
- Features our exclusive punched design providing excellent traction while preventing buildup of mud, slush, ice or debris
- Curbs provide an increased margin of safety
- Steel bolt-on legs



Model #	Size W x L	Capacity	Leg Length	Max Height Diff	Weight
AHTD-3036	30" x 36"	800 lbs	7"	5"	27 lbs
AHTD-3048	30" x 48"	800 lbs	9"	7"	35 lbs

- 4th wheel attachment takes the load off the operator
- Latch keeps the 4th wheel up and out of the way when not in use
- Lightweight design weighs only 8 lbs!
- 600 lb capacity
- Attaches to Liberator and S-Series Trucks
- Optional latch system locks the 4th wheel to prevent accidental closing (2002-E37L)
- Smooth rolling TPR casters

(Not compatible with stair climbers or convertible trucks.)



Optional cylinder attachment carries large tanks. (2002-E43)



Optional wings provide additional support for large boxes.(2002-E30)

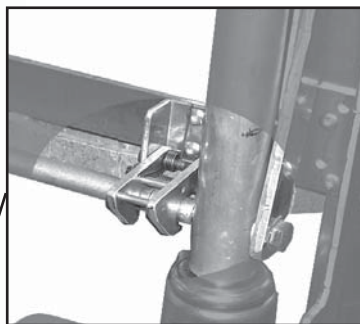
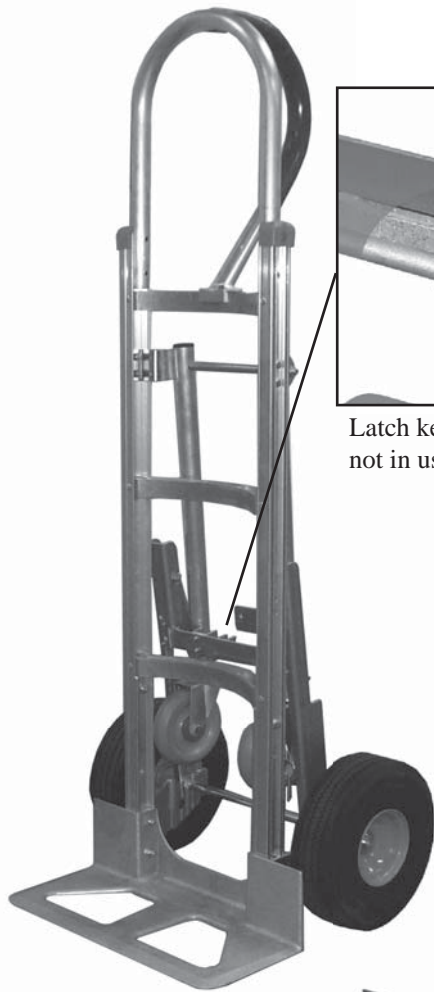

Latch keeps 4th wheel up when not in use.

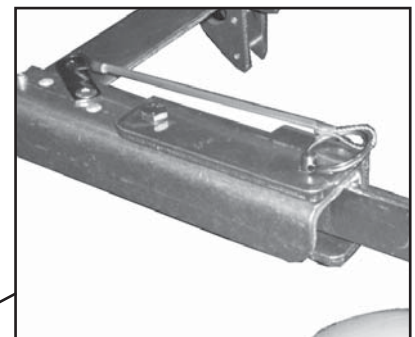

Latch and pin system keeps the 4th wheel extended (2002-E37L)

— “Three Way” Liberator Hand Truck — 19

Engineered for Bottled Water, Ice and Other Delivery Professionals



**Truck Locks Securely in Any of the
Three Positions for Safety**

- Standard with 18” x 7.5” cast noseplate and 10” pneumatic tires with precision bearings
- Integral 27” folding nose for large loads stores out of the way when not in use

Other noseplates and wheels available
Consult factory for details

Specifications

Height in 2 wheel position	52”
Height in 4 wheel position	42”
Deck Area	51” x 12”
Deck Height	11”
Capacity in 2 wheel position	600 lb.
Capacity in 4 wheel position	900 lb.
Weight (as shown)	48 lb.



B60 CA2 D5

New Design!**IC-1**

- Riveted construction for durability
- 8" balloon cushion wheel (D11) standard
- 18" slatted nose standard
- Aircraft grade cables support nose
- Engineered housing supports axle and allows use of stairclimbers



Shown with optional stairclimbers
Model # IC-1-E1L

Wheel Options

- D11 8" balloon cushion standard
D1 8" tpr, dark gray non-marking
D9 8" pneumatic
D12 8" mold-on rubber, aluminum core

Noseplate Options

- 18" slatted nose standard
18S 18" solid nose
24SL 24" slatted nose
24S 24" solid

Bakery Cart

- Solid back and large noseplate to handle bulky baked goods, trays and boxes
- Skids allow cart to slide easily up and down truck beds and loading ramps

- Width 20"
Height 52"
Noseplate (C10) 20"W x 9"D

Wheel Options

- D5 shown 10" Pneumatic
D10 10" Balloon Cushion
D11 8" Balloon Cushion

B9-C10-D5-E15-E18 Shown with D5 wheels and optional Frame Extension (E15) and E18 skids for 10" wheels
(Note: Use E14 skids with 8" wheels, E18 skids with 10" wheels)

Totally New Curb Ramp Design Makes All Other Curb Ramps OBSOLETE!



- Our exclusive process punches holes in the material, then raises the edges of the cutouts for superior traction
- Exceptionally lightweight
- Won't collect ice, mud, snow, or debris
- Handle slot doubles as a stop

Part #	Capacity	W" x L"	Weight
CRP2618	750 lb	26 x 18	8 lb
CRP2727	750 lb	27 x 27	13 lb
CRP2736	750 lb	27 x 36	17.5 lb
CRP3030	750 lb	30 x 30	15 lb
CRP2745	500 lb	27 x 45	22 lb



- Wedge design curb ramp features the same punched design for traction
- Sides folded down keep the ramp in place and allows more usable width
- 600 lb. capacity in a curb ramp weighing only 6 lb (22x24)

Part #	Capacity	W" x L"	Weight
CRW2224	600 lb	22 x 24	6 lb
CRW2724	750 lb	27 x 24	12 lb

WALKBOARDS

- Lightweight, one piece design is resistant to bending and fatigue
- Ideal for spanning between truck and loading dock
- Punched design won't collect ice, mud, snow, or debris

Part #	Capacity	W" x L"	Weight
LWB2448	750 lb	24 x 48	39 lb

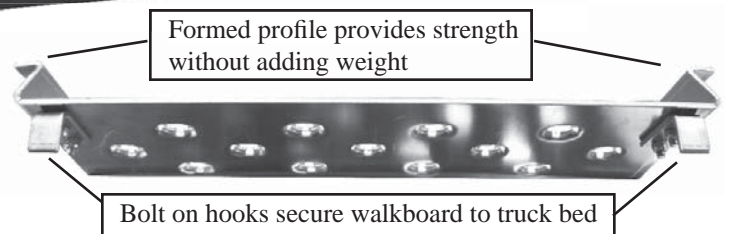
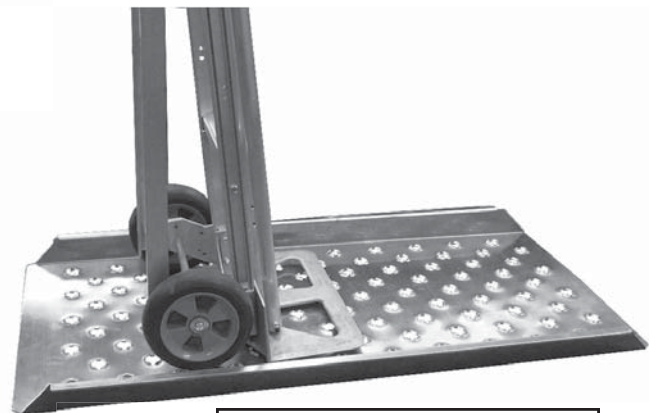

Heavy Duty Food Service Trucks

- Automotive style, dual disc brakes provide the ultimate in driver control and safety
- Total stopping power for the heaviest loads
- Braking is not affected by rain, snow, mud, or slush
- New cable actuated design is virtually maintenance free and provides equal stopping power to both wheels for consistent braking action with no pulling left or right
- Available with pneumatic tires, foam tires, and our slime treated pneumatic tires for the ultimate in flat-free performance

Available in most handle styles

Order trucks complete, or kits are available to install on Liberator hand trucks.



A4-B1-C6-D5-E1L-E13-BDC



A47-B1-C6-D5-BDC

E29 Pull Bar
Gets the hand truck out from under loads and makes it easier to lift into trailer

E13 Kick Bar
Make easy work of kicking loads back



A8-B1-C6-D5-E1L-E13-E29-E31-BDC



A43-B2-C6-D5-E1L-E13-BDC



A6-B1-C6-D5-E1L-E13-BDC

See complete list of components to build your own hand truck on page 7-10

Add Our Double Disc Brake Kit to Liberator Hand Trucks

- Our kits have everything you need to upgrade your Liberator hand truck to the ultimate brake truck - Kits include handles where necessary, all levers, cables, hardware, and a detailed installation guide
- Choose your kit below based on your specific handle and wheel combination
- New lever/cable system eliminates T-rods and provides excellent leverage in an ergonomic design
- Double disc design provides load control while allowing wheels to turn independently

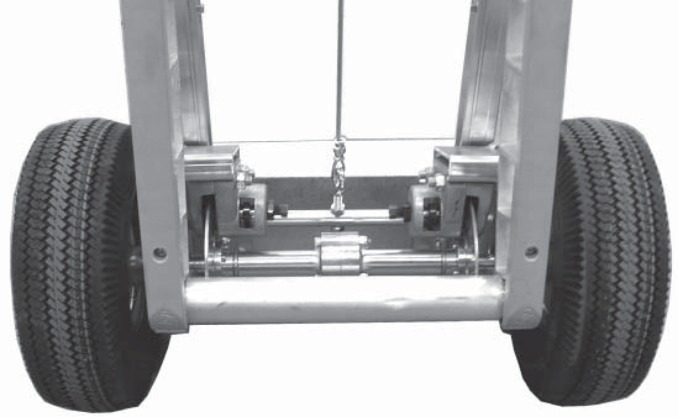

Fits A1, A2, A13 and A14
(Handle sold separately)

D5 Tire 2005-BDCA1D5
D5S Tire 2005-BDCA1D5S
D6 Tire 2005-BDCA1D6



A3, A4, A5 and A6
(Includes Handle)

A3
D5 Tire 2005-BDCA3D5
D5S Tire 2005-BDCA3D5S
D6 Tire 2005-BDCA3D6

A4
D5 Tire 2005-BDCA4D5
D5S Tire 2005-BDCA4D5S
D6 Tire 2005-BDCA4D6

A5
D5 Tire 2005-BDCA5D5
D5S Tire 2005-BDCA5D5S
D6 Tire 2005-BDCA5D6

A6
D5 Tire 2005-BDCA6D5
D5S Tire 2005-BDCA6D5S
D6 Tire 2005-BDCA6D6



Fits A11, A40, A41, A42, A43, A44
(Handle sold separately)

D5 Tire 2005-BDCA11D5
D5S Tire 2005-BDCA11D5S
D6 Tire 2005-BDCA11D6



A12 and A21
(Includes Handle)

A12
D5 Tire 2005-BDCA12D5
D5S Tire 2005-BDCA12D5S
D6 Tire 2005-BDCA12D6

A21
D5 Tire 2005-BDCA21D5
D5S Tire 2005-BDCA21D5S
D6 Tire 2005-BDCA21D6



A7, A8 and A9
(Includes Handle)

A7
D5 Tire 2005-BDCA7D5
D5S Tire 2005-BDCA7D5S
D6 Tire 2005-BDCA7D6

A8
D5 Tire 2005-BDCA7D5
D5S Tire 2005-BDCA7D5S
D6 Tire 2005-BDCA7D6

A9
D5 Tire 2005-BDCA7D5
D5S Tire 2005-BDCA7D5S
D6 Tire 2005-BDCA7D6

Reduce risk of fatigue and injury!

- 600 lb. capacity (with specified wheels)
- 4 sided frame crossmembers for rigidity
- Attached with 700 pound rated aircraft rivets
- Exclusive logo channel - Provides identity and unsurpassed fatigue resistance
- Non cracking, high strength extruded aluminum noseplates
- High tensile steel axle - standard
- Extruded axle brackets for strength and impact resistance
- Extruded - not cast - stairclimbers

BACKED BY A TWO YEAR WARRANTY!



"We have sold and serviced brake trucks for years and find that B&P works the best and requires virtually no maintenance"

-Southern Distributor

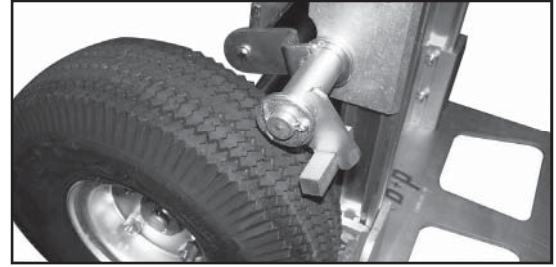

Brake shoes contact the front of the wheel, not the top or back. This prevents the possibility of locking up due to low tire pressure. Angled raking surface provides more friction on the tire than paddle designs, increasing stopping power.



Our unique lightweight tread brake design applies even pressure to both wheels assuring load control even in wet conditions. New cable design eliminates T rods and provides excellent leverage in an ergonomically correct design. Modular design allows for easy repair of damaged components.



A1-B1-C8-D5-BTC

A5-B1-C8-D5-BTC

A8-B1-C8-D5-BTC

We Have Taken Our Proven Tread Brake System and **Made it Better!**

- We have engineered a lever and cable system for the handles which provides more leverage than previous systems and offers a more ergonomically correct design.
- The lower pull bar has been upgraded to eliminate the clevis. The eye bolt goes directly through the pull bar, allowing more adjustment than before.
- Previous tread brake systems are easily upgraded.

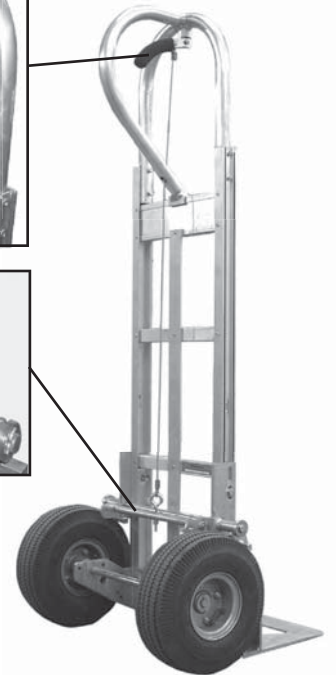

Fits A1, A2, A13 and A14
(Handle sold separately)

Part #2005-BTCA1



Fits A11, A40, A41, A42, A43, A44

(Handle sold separately)

Part #2005-BTCA11



A3, A4, A5 and A6
(Includes Handle)

Part #2005-BTCA3

Part #2005-BTCA4

Part #2005-BTCA5

Part #2005-BTCA6



A12 and A21
(Includes Handle)

Part #2005-BTCA12

Part #2005-BTCA21



A7, A8, and A9
(Includes handle)

Part #2005-BTCA7

Part #2005-BTCA8

Part #2005-BTCA9



- Pre-load by account at the warehouse - carry only what you need, reducing fuel costs
- Eliminate picking on the street - Keeps product out of the elements and reduces the risk of injuries associated with bay trucks
- Average 40 cases per cart vs 10 for a hand truck - Reduce the number of trips by up to 400%
- Straight trucks instead of bay trucks - lower initial cost and lower maintenance costs
- Faster check-in time - Reduce account service times by up to 50% increasing customer satisfaction

TWO YEAR WARRANTY

- Increase Efficiency
- Reduce Risk of Injuries
- Lower Maintenance Costs
- Better Driver Retention

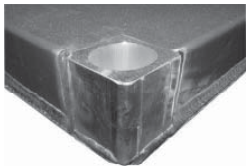
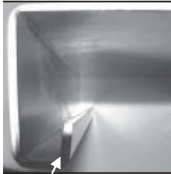
**INCREASED
BOTTOM LINE!****THE BEST BUILT, BEST BACKED CART!**

- Heavy duty deck with double bracing is a full 1/8" thick
- Formed, one piece deck won't curl like welded deck designs
- Monolithic design virtually eliminates deck twisting and failure due to fatigue
- Fully welded handle pockets - Stronger and longer lasting
- Handles are round, heavy wall aluminum for excellent resistance to bending and breaking
- Handles stay in place while in use, yet easily removable for loading/unloading

EXCLUSIVE CENTER BRAKE SYSTEM

- Brake system locks both center wheels for loading/unloading and transportation
- Actuated from either end or either side
- No unexpected cart movement

*Free Freight Program does not apply to Bulk Delivery Carts.

Optional Removable Shelf (200 lb. capacity)



FHE-1

- 18" x 60" deck
- Two handles with 2 crossbars, 1 vertical strap, and buttons for containment curtain (part # each handle 2025-134)
- 8" x 2" Urethane center wheels (part #8057-114)
- 6" x 2" TPR square tread swivel casters (part #8057-038)
- 1200 lbs capacity
- Weight 90 lbs

TO ORDER WITH BRAKE OPTION
ORDER **FHE-1B** Weight 97 lbs

FHE-6 Walkie Rider Cart



Pictured with #207 Handles

- 18" x 60" deck
- Allows 2 carts to sit side by side on walkie riders or forklifts
- Steel Understructure
- Accepts forks up to 10 1/2" wide
- Requires only 7" between forks
- 1200 lbs capacity
- Weight 90 lbs

*Walkie Rider Not available with brake

Standard Understructure

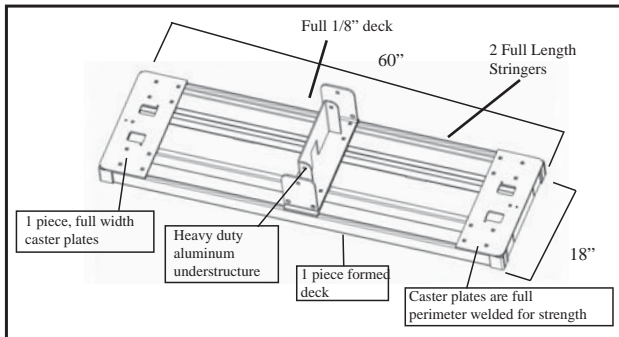

Walkie Rider Understructure

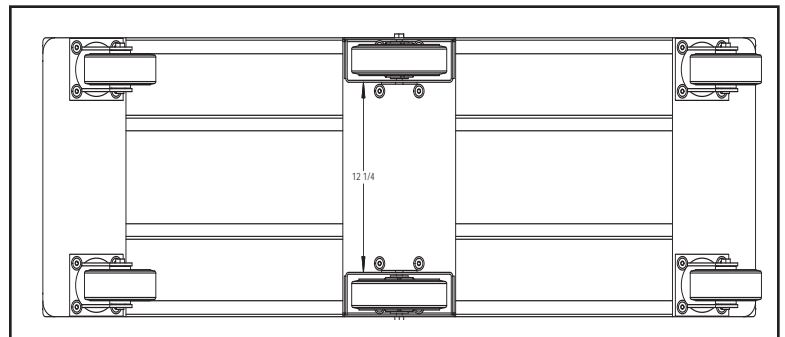

HANDLE OPTIONS/REPLACEMENT HANDLES

2 STANDARD ON ABOVE CARTS
(#204 Handle Option)

2 Crossbars/1 Vertical Strap, 3/16" thick
Buttons for containment curtain
(To order replacements order
Part # 2025-134)

(If buttons for containment
curtain are not required order
part number 2025-103)

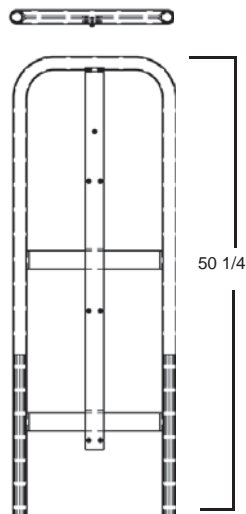

ALSO AVAILABLE:
(Order #207 Handle Option)

2 Crossbars/1 Vertical Strap,
Buttons for containment curtain
(To order replacements order
Part # 2025-130)

(If buttons for containment
curtain are not required order
part number 2025-131)

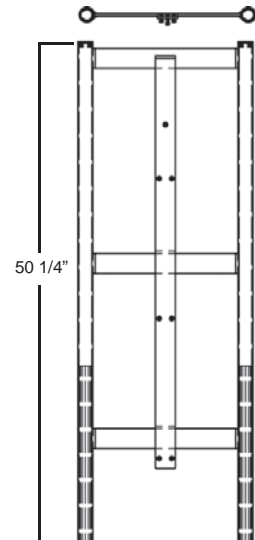

28 — Bulk Delivery Cart Accessories —



CANVAS
Part # 2025-503



MESH
Part # 2025-505

- **Product Containment Curtain** that works!
- Available in canvas (part # 2025-503) and mesh (part # 2025-505)
- Eliminate costly and unsightly stretch wrap
- Keeps load secure
- Straps don't drag on the ground
- Steel strap clips won't break



Liberator Keg Hauler
Part # KEG-1

- Hauls 6 full half barrels!
 - Lightweight extruded tubular aluminum design.
 - Locking tabs keep KEG-1 in place yet removes easily with integrated handles
- Fits 60" and 61" carts (18" width)

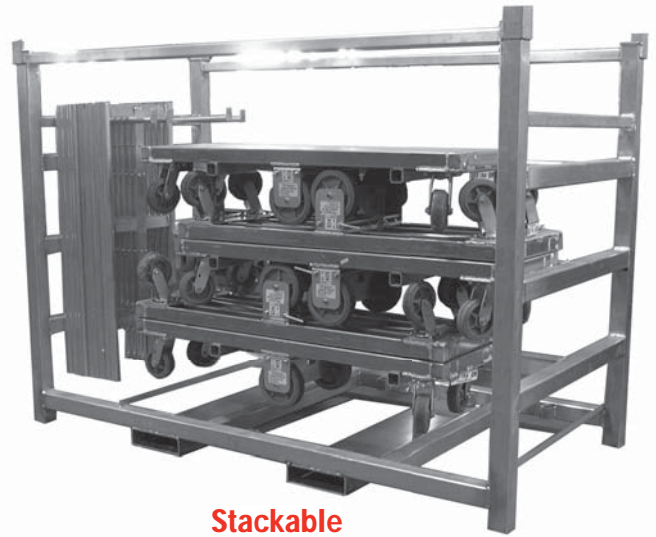

Stackable
Bulk Delivery Cart Storage Rack
Part # 2026-001

- Maximize Warehouse Space - Cart rack has a capacity to hold 14 carts and 28 handles
 - Aluminum Construction - Makes the cart rack strong and last long
 - Convenient way to store multiple bulk delivery carts in one place with the ability to stack 3 cart racks high
- 51" Deep, 96" Wide, 68 1/2" High
Weight 210 lbs empty
Max Height 207" (3 High Requires 20 Ft. Ceiling Minimum)

Part # NCR2745

Curb Ramp for use with Bulk Delivery Cart
1/4" Smooth Plate with Non-Skid Tape
27" Wide x 45" Long
1400 Lb Capacity
Weight 34 Lb

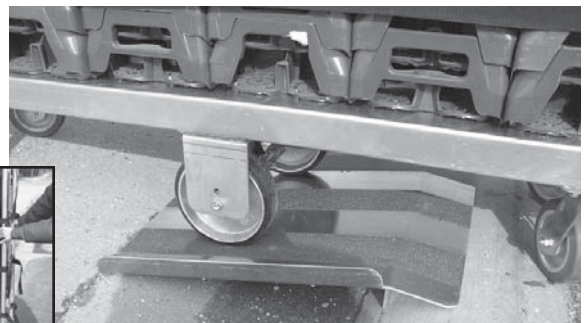

We are the experts in bulk delivery!

Call one of our product experts to design a cart to suit your specific application.

Universal Bulk Delivery Square Pocket Design



Square Handle Fits Competitor Models

From Casters to Complete Carts, B & P Manufacturing Offers the Guaranteed Best in Bulk Delivery Systems

FHM-1

- 18"x60" smooth deck, square pockets
- 8" rigid urethane center casters (P/N 8057-007)
- 8" TPR swivel casters (P/N 8057-017)



- Replace casters or upgrade to our exclusive heavy duty understructure.

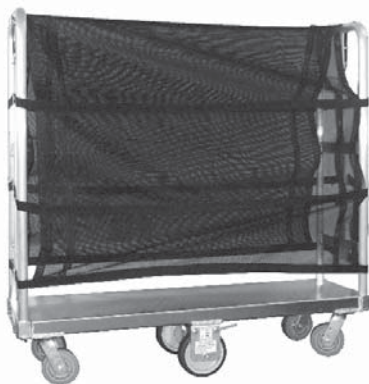

- Product containment curtain for 60" carts. Replace torn curtains with our unique design, providing more durable metal clips.
- Available in Mesh (P/N 2025-506) or Solid Canvas (P/N 2025-507)

NEW STRONGER HANDLE

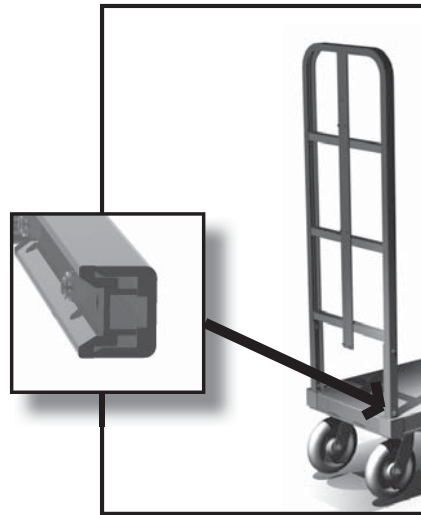

- Replacement handles feature a more ergonomic handle design that reduces driver hand fatigue. (P/N 2025-165)

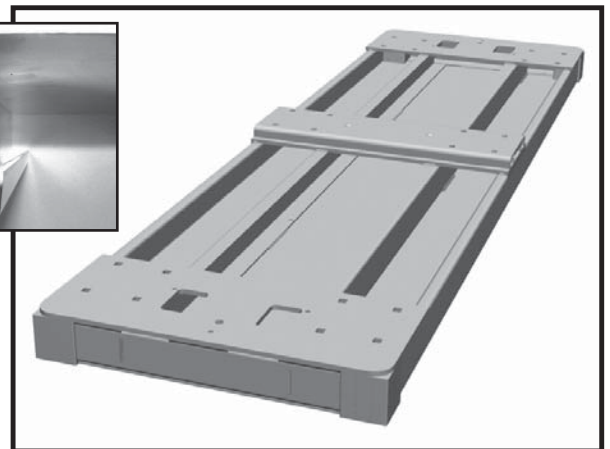
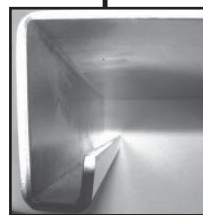

- Replacement decks feature our more durable formed design.
- Square pockets accept competitor handles. (P/N FHS-1860S)

With Heavy Duty Understructure - **FHS-1**

With Heavy Duty Understructure and Brake - **FHS-1B**

Model shown FHE-2460-217-HD10-SH with square handles and shelf option



- 24" wide x 60" long deck
- Two handles with two crossbars and one vertical strap
- 8" x 2" urethane center wheels (part # 8057-114)
- 6" x 2" TPR square tread swivel casters (part # 8057-038)

Capacity 1,200 lb

- Optional removable shelf (add -SH to model #)
Capacity 200 lb
- Optional center brake (add -CB to model #)

Retail Beverage Pre-Cool Cart Model # MAC-12

- Keeps product cold in walk in coolers
- Save precious cooler space
- Easily transports to point of sale coolers
- Reduce customer complaints due to warm product
- Eliminate stock rotation

24" Wide x 58.88" Overall Length x 61" Overall Height
8" x 2" TPR Center Wheels (p/n 8057-018)
6" x 2" TPR Swivel Casters (p/n 8057-038)

750 lb capacity - Shelf capacity 250 lb



- Tilt design allows easy maneuvering in tight places
Spins on it's own axis
- Folds flat for compact storage, reducing shipping costs
- Lightweight design is easily transported
- Heavy duty understructure for maximum durability
- Non marking wheels for in store use
- Modular construction for easy replacement of damaged components
- Adjustable/removable shelf to accommodate a variety of products
- Adjustable handle height



Aluminum Dockboard with Steel Curbs

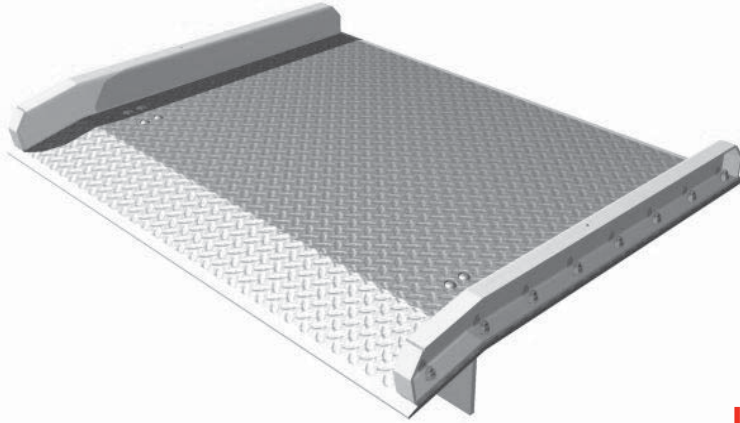

- **Lightweight Aluminum Deck With Safety Treadplate Surface**
- **Heavy Duty Bolt-On Steel Curbs** for strength. Helps prevent run off. High visibility orange for safety.
- **Beveled Edges** provide smooth entry and exit.
- **Engineered Bend** keeps the edges of the dockboard flush with both dock and truck.
- **Heavy Duty Steel Bolt-On Legs** can be reversed for refrigerated applications.

Industry Exclusive Two Year Warranty

SPECIFICATIONS			10,000 LB CAPACITY 3/8" Aluminum, 4" High Steel Curbs			15,000 LB CAPACITY 1/2" Aluminum, 4" High Steel Curbs		
Size (WxL)	Max Height Difference	Leg Length	Cap. (Lbs)	Model #	Wt (Lbs)	Cap. (Lbs)	Model #	Wt (Lbs)
60" x 36"	5"	7"	10,000	ADS10-6036	126	15,000	ADS15-6036	153
60" x 48"	7"	9"	10,000	ADS10-6048	169	15,000	ADS15-6048	204
60" x 60"	10"	12"	10,000	ADS10-6060	211	15,000	ADS15-6060	255
60" x 72"	12"	18"	10,000	ADS10-6072	261	15,000	ADS15-6072	314
72" x 36"	5"	7"	10,000	ADS10-7236	174	15,000	ADS15-7236	193
72" x 48"	7"	9"	10,000	ADS10-7248	190	15,000	ADS15-7248	255
72" x 60"	10"	12"	10,000	ADS10-7260	237	15,000	ADS15-7260	322
78" x 36"	5"	7"				15,000	ADS15-7836	178
78" x 48"	7"	9"				15,000	ADS15-7848	238
78" x 60"	10"	12"				15,000	ADS15-7860	297
78" x 72"	12"	18"				15,000	ADS15-7872	357

"Quick Ship" available on all sizes

Accessories

Lifting Chains

Heavy duty chains for forklift moving of dockboards

Quickly and easily attached onto the dockboard curb with heavy duty steel hooks

(Recommended for boards 10,000 lb capacity and up)

*See page 33 for replacement leg sizes and part numbers

Aluminum Dockboard with Welded Aluminum Curbs

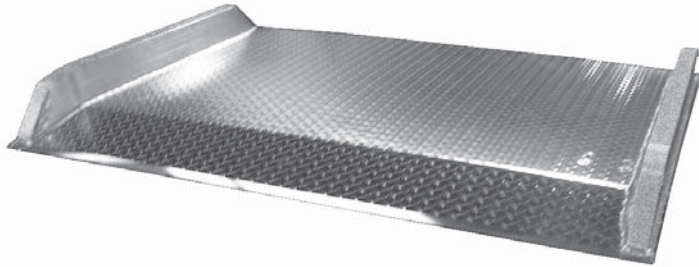

- FULLY WELDED ALUMINUM CURBS FOR MAXIMUM STRENGTH AND DURABILITY
- STEEL BOLT-ON LEGS
- INDUSTRY EXCLUSIVE TWO YEAR WARRANTY
- QUICK-SHIP AVAILABILITY ON POPULAR SIZES

SPECIFICATIONS			5,000-7,000 LB CAPACITY 5/16" Aluminum, 3" High Curb (if noted with * plate is 3/8" Alum)			10,000 LB CAPACITY 3/8" Aluminum, 3.5" High Curb			12,000-15,000 LB CAPACITY 3/8" Aluminum, 4" High Curb			12,000-17,000 LB CAPACITY 1/2" Aluminum, 4" High Curb		
Size (W x L)	Max Height Difference	Leg Length	Cap. (Lbs)	Model #	Wt (Lbs)	Cap. (Lbs)	Model #	Wt (Lbs)	Cap. (Lbs.)	Model #	Wt (Lbs)	Cap. (Lbs)	Model #	Wt (Lbs)
48"x36"	5"	7"	7,000	L7-4836	80	10,000	L10-4836	97						
48"x48"	7"	9"	7,000	L7-4848	107	10,000	L10-4848	130						
48"x60"	10"	12"	7,000	L7-4860	133	10,000	L10-4860	162						
60"x36"	5"	7"	7,000	L7-6036	93	10,000	L10-6036	113	15,000	L15-6036	120	17,000	L17-6036	146
60"x48"	7"	9"	7,000	L7-6048	124	10,000	L10-6048	151	15,000	L15-6048	160	17,000	L17-6048	195
60"x60"	10"	12"	7,000	L7-6060*	155	10,000	L10-6060	188	15,000	L15-6060	200	17,000	L17-6060	244
60"x72"	12"	18"	5,000	L5-6072*	193				12,000	L12-6072	248	15,000	L15-6072	300
72"x36"	5"	7"	5,000	L5-7236	106				12,000	L12-7236	136	15,000	L15-7236	167
72"x48"	7"	9"	5,000	L5-7248	141				12,000	L12-7248	181	15,000	L15-7248	223
72"x60"	10"	12"	5,000	L5-7260*	177				12,000	L12-7260	226	15,000	L15-7260	279
72"x72"	12"	18"										12,000	L12-7272	342

Popular sizes in bold print available for "Quick Ship" upon request

Accessories

Handles

Add lift handles for easy movement
(Only available on 5,000 and 7,000 capacity boards)

Lifting Chains

Heavy duty chains for forklift moving of dockboards

Quickly and easily attached onto the dockboard curb with heavy duty steel hooks

(Recommended for boards 10,000 lb capacity and up)

How to choose a Dockboard:

Step 1: Determine capacity - add the weight of the forklift and the weight of the maximum load to be carried

Step 2: Determine Width - The width of the dockboard should be at least 18 inches wider than your widest equipment passing over the board. Remember, safety curbs take up 6 inches of usable width.

Example: A 60 inch dockboard has 54 inches of usable space.

Step 3: Determine Length - You need to know the maximum difference between the height of the dock and the height of the highest truck bed.

1. Max. Truck Height	
2. Minus Dock Height	-
3. Equals Height Difference	=

Using the chart below, determine the length of the board you need. An 11 degree bend is standard. Example: If the maximum height difference is 7 inches, a board at least 48 inches long is required.

	MAXIMUM HEIGHT DIFFERENCE (INCHES)																	
SLOPE ANGLE	1	2	3	4	5	5.5	6	7	8	8.5	9	10	11	12	13	14	15	16
11 DEG. STANDARD				30	36		42	48		54		60	66	72	78	84	90	96

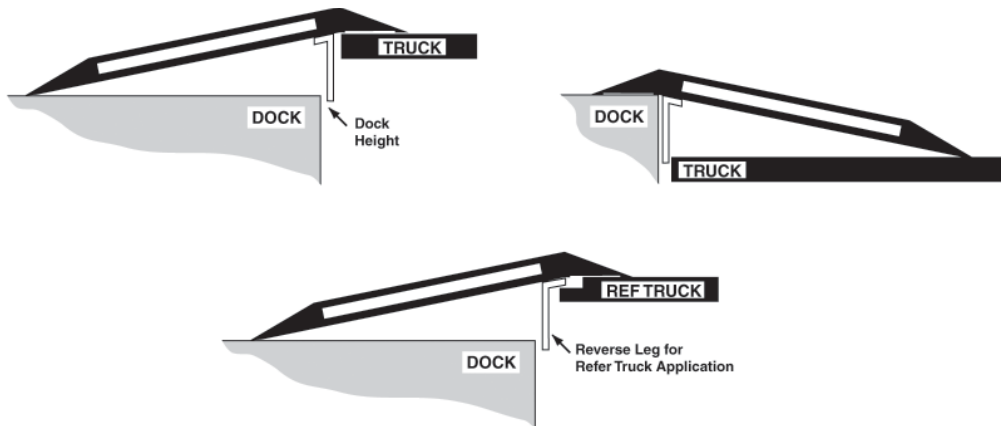

To Order Replacement Legs:

BOARD LENGTH	LEG LENGTH	TO ORDER 1 LEG (NO HARDWARE)	TO ORDER A PAIR OF LEGS (INCLUDES HARDWARE)
36 inches	7 inch	P/N 8062-001	P/N 3500-L7
48 inches	9 inch	P/N 8062-002	P/N 3500-L9
60 inches	12 inch	P/N 8062-003	P/N 3500-L12
72 inches	18 inch	P/N 8062-004	P/N 3500-L18

Best Selling Dockplates in America

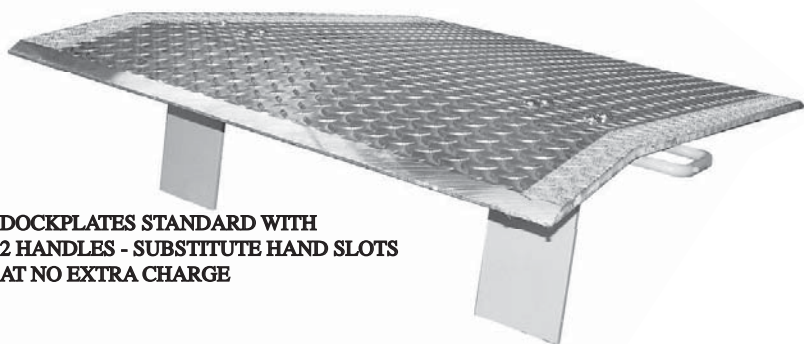

DOCKPLATES STANDARD WITH 2 HANDLES - SUBSTITUTE HAND SLOTS AT NO EXTRA CHARGE

- **High-Traction, Safety Treadplate Surface** gives positive traction for equipment and safe footing for personnel.
- **Bolt-On Legs/Handles** allow for quick field repair and ease of moving/lifting - Easily reversed for refrigerated trucks.
- **Beveled Edges** provide smooth entry and exit.
- **Engineered Bend** keeps the edges of the dock plate flush with both dock and truck.
- **Safety Yellow Tape** on edges for low light visibility

Two Year Warranty

How To Select The Correct Dockplate: NON MOTORIZED USE ONLY!

Step 1: Determine Width - add 12" to the widest load that will go over the plate

Step 2: Determine Capacity - weight of pallet jack + maximum weight of items carried + operator weight

If the maximum load is within 50 pounds of the stated capacity, select the next highest capacity.

Step 3: Determine Length - required length is determined by height difference between dock and truck floor

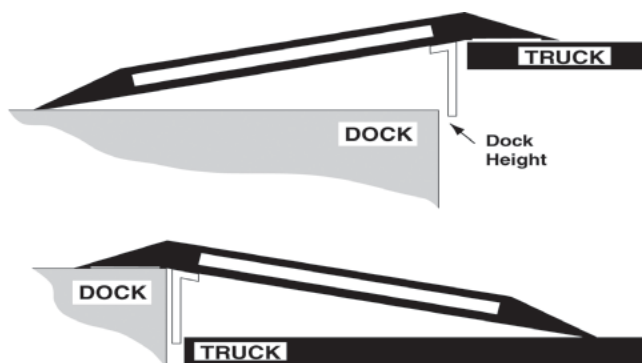

SLOPE ANGLE	MAXIMUM HEIGHT DIFFERENCE IN INCHES																	
	1	2	3	4	5	5.5	6	7	8	8.5	9	10	11	12	13	14	15	16
11 DEG. STANDARD				30	36		42	48		54		60	66	72	79	84	90	96

A Note About Capacities

All B&P dockplates are rated at actual capacities, per Aluminum Industry Association standards. Some other companies rate capacities with a formula that considers the fact that only two wheels of the four wheel vehicle will be on the plate at one time. This can artificially overstate the capacities of the plates, creating a potentially dangerous situation. We state our capacities as actual, giving you an extra margin of safety.

Dockplates are standard with 2 handles - Order with hand slots at no additional charge

SPECIFICATIONS			EL SERIES 5/16" Plate			E SERIES 3/8" Plate			EH SERIES 1/2" Plate		
Size (w x l)	Max Ht. Diff (In)	Leg Length	Cap. (Lbs)	Model #	Weight (Lbs)	Cap. (Lbs)	Model #	Weight (Lbs)	Cap. (Lbs)	Model #	Weight (Lbs)
30x24	3	7	2196	EL-3024	42	3000	E-3024	46	5200	EH-3424	55
30x30	4	7	1757	EL-3030	47	2300	E-3030	53	4100	EH-3030	64
30x36	5	7	1464	EL-3036	53	1800	E-3036	60	3500	EH-3036	72
30x48	7	9	1098	EL-3048	68	1400	E-3048	76	2600	EH-3048	94
36x24	3	7	2636	EL-3624	46	3600	E-3624	51	6200	EH-3624	62
36x30	4	7	2108	EL-3630	53	3000	E-3630	58	5100	EH-3630	72
36x36	5	7	1757	EL-3636	59	2500	E-3636	68	4300	EH-3636	82
36x48	7	9	1318	EL-3648	76	1900	E-3648	87	3000	EH-3648	108
42x24	3	7	3075	EL-4224	51	4300	E-4224	57	7200	EH-4224	68
42x30	4	7	2460	EL-4230	58	3300	E-4230	64	5900	EH-4230	81
42x48	7	9	1537	EL-4248	85	2100	E-4248	96	3500	EH-4248	123
48x24	3	7	3514	EL-4824	55	5200	E-4824	62	8200	EH-4824	75
48x30	4	7	2811	EL-4830	64	4100	E-4830	72	6300	EH-4830	90
48x36	5	7	2343	EL-4836	72	3500	E-4836	83	5300	EH-4836	104
48x42	6	9	2008	EL-4842	85	3000	E-4842	96	4300	EH-4842	122
48x48	7	9	1757	EL-4848	94	2600	E-4848	107	3800	EH-4848	137
48x60	10	12				1800	E-4860	132	2900	EH-4860	168
60x24	3	7	4393	EL-6024	64	5700	E-6024	71	10000	EH-6024	90
60x30	4	7	3514	EL-6030	75	4600	E-6030	85	7800	EH-6030	108
60x36	5	7	2928	EL-6036	85	4100	E-6036	98	6600	EH-6036	125
60x42	6	9	2510	EL-6042	100	3500	E-6042	115	5500	EH-6042	148
60x48	7	9	2196	EL-6048	111	2900	E-6048	129	4800	EH-6048	164
60x60	10	12				2000	E-6060	160	3700	EH-6060	203
72x30	4	7	4217	EL-7230	85	5400	E-7230	98	9500	EH-7230	125
72x36	5	7	3514	EL-7236	99	4300	E-7236	118	7800	EH-7236	145
72x48	7	9	2636	EL-7248	129	3400	E-7248	151	5900	EH-7248	191

*Popular sizes in bold print available for "Quick Ship" upon request

TO ORDER REPLACEMENT LEGS:

Leg & Handle Assy (pair w/hardware)

- 7" Legs **Part #3500-L7H2**
- 9" Legs **Part #3500-L9H2**
- 12" Legs **Part #3500-L12H2**

1 Leg w/Handle (does not include hardware)

- 7" Leg w/Handle LH **Part #8220-001**
- 7" Leg w/Handle RH **Part #8220-002**
- 9" Leg w/Handle LH **Part #8220-003**
- 9" Leg w/Handle RH **Part #8220-004**
- 12" Leg w/Handle LH **Part #8220-005**
- 12" Leg w/Handle RH **Part #8220-006**

For Plates with Hand Slots (pair of Legs w/hardware)

- 7" Legs **Part #3500-L7**
- 9" Legs **Part #3500-L9**
- 12" Legs **Part #3500-L12**

1 Leg Only - No Handle (does not include hardware)

- 7" Leg Only/No Handle **Part #8062-001**
- 9" Leg Only/No Handle **Part #8062-002**
- 12" Leg Only/No Handle **Part #8062-003**

Leg Hardware Kit **P/N 3500-H1** - includes 8 carriage bolts and 8 nylock lock nuts

AVAILABLE IN FORMED DECK OR WELDED DECK DESIGN***BOTH FEATURING A TWO YEAR WARRANTY!*****EXCLUSIVE FORMED DECK DESIGN**

- Strong and lightweight
- Design eliminates warping and waving
- High capacity
- Tread plate or smooth plate deck
- Handle and caster options for most applications



PTF-3048S-150-850
 30" x 48" smooth plate deck
 one standard #150 handle
 8"x2" TPR casters
 (2 swivel, 2 rigid)
 2,000 lb capacity



PTF-3048T-150-850
 30" x 48" tread plate deck
 one standard #150 handle
 8"x2" TPR casters
 (2 swivel, 2 rigid)
 2,000 lb capacity

HEAVY DUTY WELDED DECK DESIGN

Industry exclusive side rails actually lock the deck in to provide strength and resistance to twisting and deck curling. The side rail also allows field installation of the protective bumper and deck carpeting. These features, combined with our standard setting heavy duty understructure, make this the best platform truck on the market, hands down.



PT-3060T-150-650
 30" x 60" tread plate deck
 one standard #150 handle
 6"x2" TPR casters
 (2 swivel, 2 rigid)
 1,500 lb capacity
 (2,000 lb capacity with
 #850 casters)

Available with Tread Plate,
 Smooth Plate, or Carpeted Decks

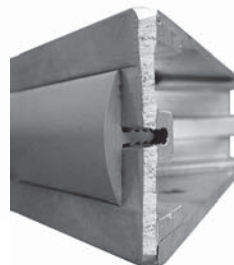

Full protective bumper available on all welded models in standard black or non-marking gray.



Shown with Full Protective Bumper
 and Carpeted Deck

PT-3060S-150-850-C-310
 30" x 60" smooth plate deck
 one standard #150 handle
 8"x2" TPR casters
 (2 swivel, 2 rigid)
 carpeted deck
 full perimeter gray bumper
 2,000 lb capacity

FORMED DECK WITH ONE #150 OPEN HANDLE

DECK SIZE	TREAD PLATE DECK	SMOOTH PLATE DECK
W" X L"	MODEL #	MODEL #
24 x 36	PTF-2436T-150	PTF-2436S-150
24 x 48	PTF-2448T-150	PTF-2448S-150
30 x 48	PTF-3048T-150	PTF-3048S-150
30 x 60	PTF-3060T-150	PTF-3060S-150
30 x 72	PTF-3072T-150	PTF-3072S-150
36 x 48	PTF-3648T-150	PTF-3648S-150

OPTIONAL HANDLES



#155 Handle
One Strap



#160 Handle
Two Straps



#165 Handle
18" Panel

WELDED DECK WITH ONE #150 OPEN HANDLE

DECK SIZE	TREAD PLATE DECK	SMOOTH PLATE DECK
W" X L"	MODEL #	MODEL #
24 x 36	PT-2436T-150	PT-2436S-150
24 x 48	PT-2448T-150	PT-2448S-150
24 x 60	PT-2460T-150	PT-2460S-150
30 x 48	PT-3048T-150	PT-3048S-150
30 x 60	PT-3060T-150	PT-3060S-150
30 x 72	PT-3072T-150	PT-3072S-150
36 x 48	PT-3648T-150	PT3648S-150
36 x 60	PT-3660T-150	PT-3660S-150
36 x 72	PT-3672T-150	PT-3672S-150

CASTER OPTIONS (2 RIGID, 2 SWIVEL)

TPR Non-Marking Casters
The Best High Performance
Caster Available

Easier, more responsive starts
and rolling than mold on rubber

Resists and rejects metal
shavings, chips and other debris

Impact resistant with
maximum shock absorption



Caster Kit 650
6"x 2", Poly Core,
Round TPR Tread
(provides 1,500 lb cap.)
add **-650** to model #



Caster Kit 850
8"x2", Poly Core
Round TPR Tread
(provides 2,000 lb cap.)
add **-850** to model #



Caster Kit 820
8" Cast Iron Core
Mold on Rubber
Square Tread
(provides 2,500 lb cap.)
add **-820** to model #

Welded Deck Design Available with
Full Perimeter Bumper

For Black add **-300** to model #

For non-marking Gray add **-310** to model #

And

Carpeted Deck, add **-C** to model #

*bumper required with carpeted deck

Optional Floor Locks

For use with 6" casters add **-060** to model #

For use with 8" casters add **-080** to model #

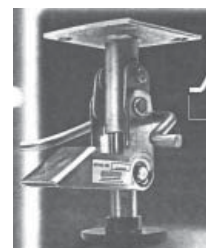

NEW DESIGN

Lighter Weight!
Improved Traction!
Built in Handles!

- Save Time and Money
- Reduce Risks of Injury and Fatigue
- Speeds Loading/Unloading
- Transports easily in your delivery vehicle
- Ideal for city deliveries where space is limited
- Widths and lengths to suit any application
- **Two Year Warranty!**

SPECIFICATIONS										
Type	Height Range (In)		Length (Ft)	Cap. Lbs.	26" Width		28" Width		38" Width	
	Min	Max			Model #	Wt (Lbs)	Model #	Wt (Lbs)	Model #	Wt (Lbs)
A	6	21	6	2000	-	-	PR-2806-A	48	PR-3806-A	61
	6	25	7	1800	-	-	PR-2807-A	56	PR-3807-A	70
	6	29	8	1700	-	-	PR-2808-A	63	PR-3808-A	79
	6	33	9	1650	-	-	PR-2809-A	70	PR-3809-A	88
	6	38	10	1500	-	-	PR-2810-A	77	PR-3810-A	97
	6	46	12	1400	-	-	PR-2812-A	92	PR-3812-A	115
	6	54	14	1200	-	-	PR-2814-A	107	PR-3814-A	133
	6	62	16	1000	-	-	PR-2816-A	121	PR-3816-A	151
F	6	23	6	2000	PR-2606-F	47	PR-2806-F	49	PR-3806-F	62
	6	27	7	1800	PR-2607-F	54	PR-2807-F	57	PR-3807-F	71
	6	31	8	1700	PR-2608-F	61	PR-2808-F	64	PR-3808-F	80
	6	35	9	1650	PR-2609-F	68	PR-2809-F	71	PR-3809-F	89
	6	40	10	1500	PR-2610-F	75	PR-2810-F	79	PR-3810-F	98
	6	48	12	1400	PR-2612-F	89	PR-2812-F	93	PR-3812-F	116
	6	56	14	1200	PR-2614-F	103	PR-2814-F	108	PR-3814-F	134
	6	64	16	1000	PR-2616-F	117	PR-2816-F	122	PR-3816-F	152



To suit your needs better, two types of ramps are available:

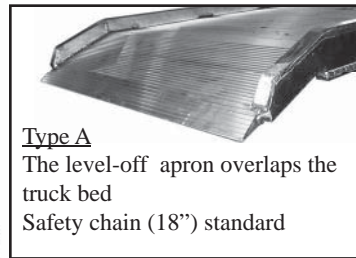

Type A
 The level-off apron overlaps the truck bed
 Safety chain (18") standard

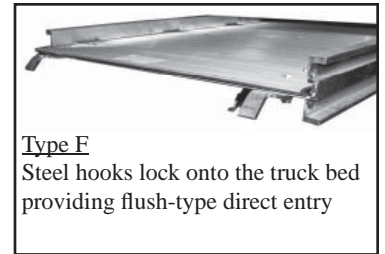

Type F
 Steel hooks lock onto the truck bed providing flush-type direct entry

OPTIONAL UNDER TRUCK CARRIERS

Available for Type F Hook End ONLY

C designates carrier, then width, length and open or closed.

Ramp Width	Ramp Length	Open Carrier P/N	Closed Carrier P/N
26"	14'	C2614O	C2614C
26"	16'	C2616O	C2614C

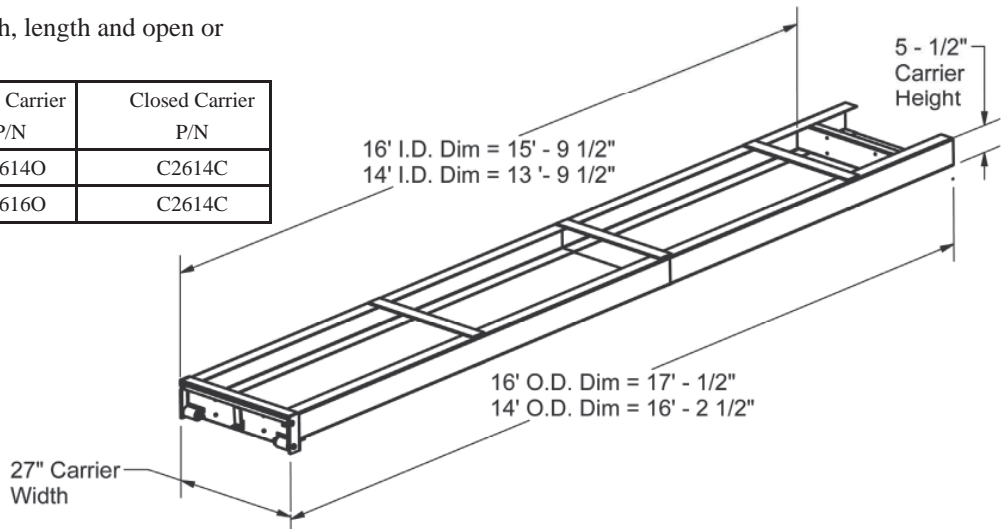

Other sizes available on a special order basis and will be non-returnable. Consult factory for pricing.

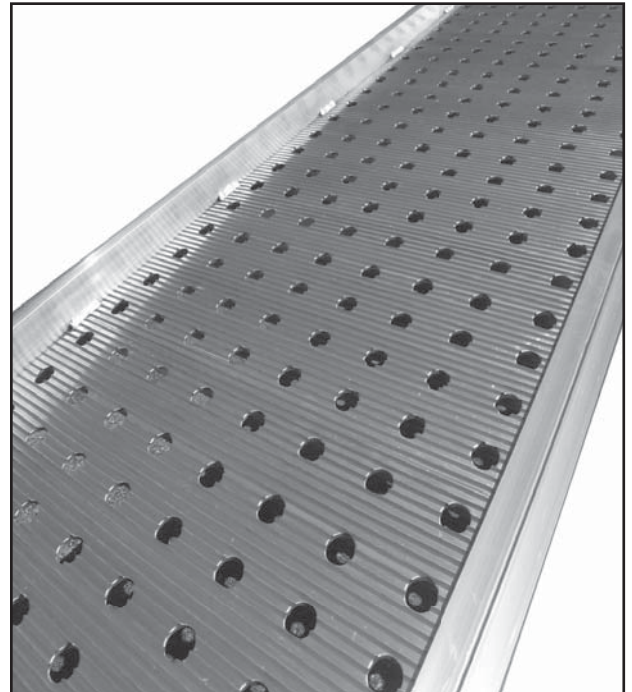

NEW PUNCHED DESIGN

- Holes are punched in the material, provides superior traction
- Won't collect ice, mud, snow, or debris
- Punched design reduces the weight without sacrificing strength
- Custom widths available
- Steel hooks lock onto truck bed for flush-type direct entry

SPECIFICATIONS									
Height Range (In)		Length (Ft)	Cap. (Lbs)	26" Width		28" Width		38" Width	
Min	Max			Model #	Wt. (Lbs)	Model #	Wt. (Lbs)	Model #	Wt. (Lbs)
6	23	6	2000	PRP-2606-F	44	PRP-2806-F	45	PRP-3806-F	58
6	27	7	1800	PRP-2607-F	51	PRP-2807-F	53	PRP-3807-F	67
6	31	8	1700	PRP-2608-F	57	PRP-2808-F	60	PRP-3808-F	75
6	35	9	1650	PRP-2609-F	64	PRP-2809-F	67	PRP-3809-F	83
6	40	10	1500	PRP-2610-F	70	PRP-2810-F	74	PRP-3810-F	92
6	48	12	1400	PRP-2612-F	84	PRP-2812-F	88	PRP-3812-F	108
6	56	14	1200	PRP-2614-F	97	PRP-2814-F	101	PRP-3814-F	125
6	64	16	1000	PRP-2616-F	111	PRP-2816-F	115	PRP-3816-F	142

Speeds Loading/Unloading and Material Movement in Warehouse or at Production Lines

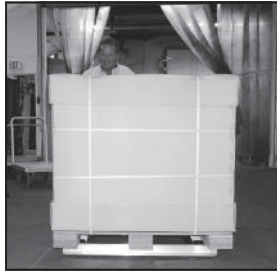

Model #4248-6T

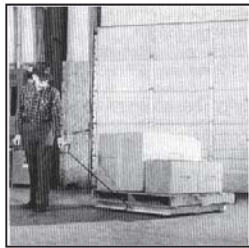

Optional Handle



Model #2424-6T

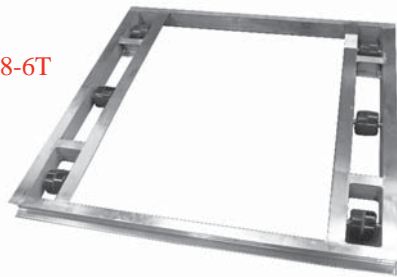

Model #4848-6T

Light - Average weight only 40 lbs. Make possible return of number of dollies to loading point manually.

Rugged - Strong extruded aluminum frame and steel axles.

Maneuverable - Tilt Construction with 360 degree turning. Non-tilt also available.

Rollers - 3.5" rollers with sealed bearings.

All Popular Sizes - From 36"x36" to 48"x48".

Capacities - 4,000 to 8,000 pounds.

Economic Benefits - Frees fork lift trucks from short hauls. Greater worker safety and reduced labor time.

Size W x L Length is Travel Direction	4,000 Lb Capacity 6 Roller		6,000 Lb Capacity 8 Roller		8,000 Lb Capacity 10 Roller	
	Model #	Wt (Lbs)	Model #	Wt (Lbs)	Model #	Wt (Lbs)
36" x 36"	3636-6T	32	3636-8T	37	3636-10T	40
36" x 42"	3642-6T	34	3642-8T	40	3642-10T	43
36" x 48"	3648-6T	36	3648-8T	41	3648-10T	44
40" x 48"	4048-6T	36	4048-8T	42	4048-10T	45
42" x 42"	4242-6T	37	4242-8T	43	4242-10T	46
42" x 48"	4248-6T	37	4248-8T	43	4248-10T	46
48" x 48"	4848-6T	38	4848-8T	44	4848-10T	47
24" x 24"	2424-6T	34				

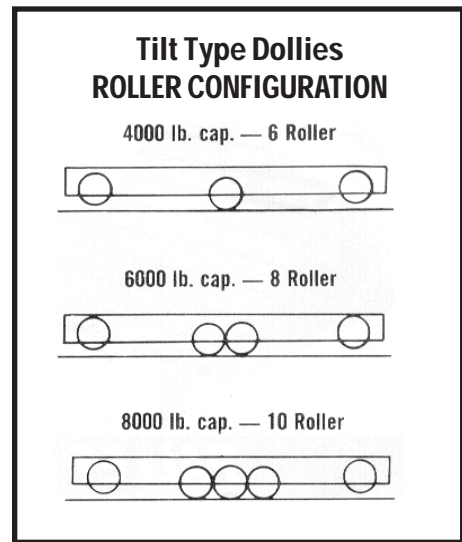

Deck option available - consult factory

Non Tilt Type

If a non-tilt type of Pallet Dolly is desired, delete the "T" and add "NT" to the model number when ordering - No extra charge for the non-tilt type dollies

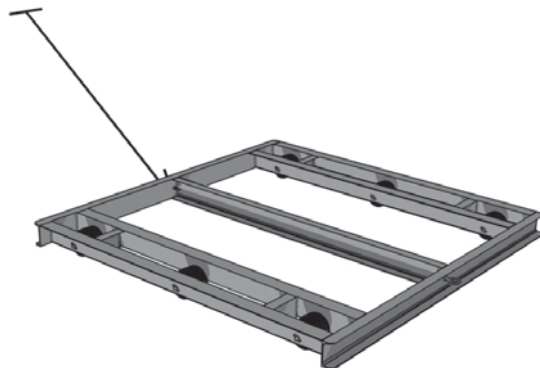

Two handle loops and one handle are available as optional equipment - push or pull either end
Add -H to model #
Example: 4848-6T-H

To order center support crossbar as an option
Add -CB to model #
Example: 3636-6T-CB

To Select Your Ramp:

Ramp selection is based on the following three items:

A Width - Based on the maximum wheel width of your largest vehicle.
For double wheel vehicles, choose the 24" width and use the ramp at the inside wheel location.

B Height - Determined by the following formula:
Dock Height + 2" = _____
minus Truck Bed Height = _____
Choose the next highest standard height in chart.

C Length - The longer the ramp, the less incline angle. Choose a length with an incline angle that your loaded vehicles can negotiate easily.

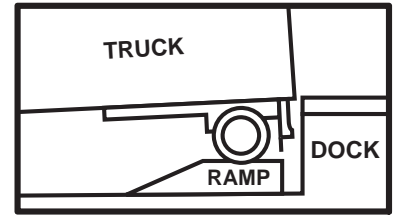
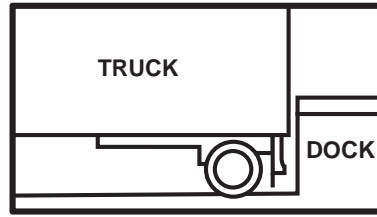

CAPACITY FOR ALL MODELS = 12,000 LBS PER RAMP							
Height (In)	Length (In)			18" Wide		24" Wide	
	Overall	Level	Incline	Model #	Wt (Lbs)	Model #	Wt (Lbs)
	6	48	30	18	PR-18-6-48	64	PR-24-6-48
60		42	18	PR-18-6-60	77	PR-24-6-60	94
102		84	18	PR-18-6-102	126	PR-24-6-102	145
8	54	30	24	PR-18-8-54	78	PR-24-8-54	94
	60	36	24	PR-18-8-60	85	PR-24-8-60	103
	108	84	24	PR-18-8-108	147	PR-24-8-108	169
10	60	30	30	PR-18-10-60	95	PR-24-10-60	115
	66	36	30	PR-18-10-66	102	PR-24-10-66	124
	72	42	30	PR-18-10-72	111	PR-24-10-72	133
	114	84	30	PR-18-10-114	166	PR-24-10-114	188
12	72	36	36	PR-18-12-72	125	PR-24-12-72	143
	78	42	36	PR-18-12-78	137	PR-24-12-78	153
	120	84	36	PR-18-12-120	188	PR-24-12-120	213

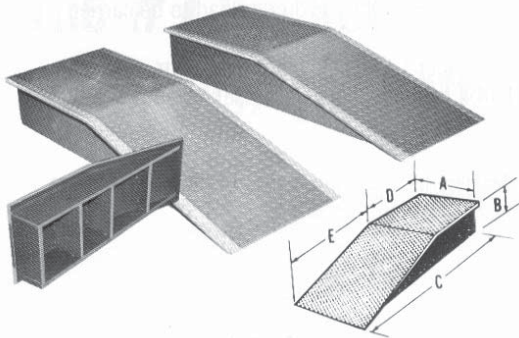

Wheel Chocks

RUBBER

MODEL #RWC-1

Rubber Construction
Ribbed Tire Face
Extra Strong, Lightweight
9 lbs. each
9.5"W x 8"H x 6"D

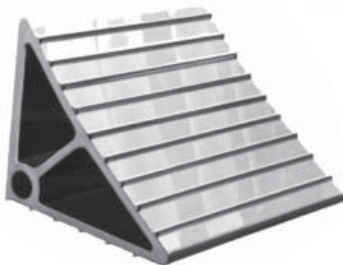

ALUMINUM

MODEL #AWC-888

Extruded Aluminum
Ribbed Tire Face
Extra Strong, Lightweight
7 lbs. each
8"W x 7.5"H x 7.5"D

ATTENTION!!

Wheels MUST BE Chocked!
AN OSHA REQUIREMENT

Optional **ANTI-PILFERAGE** Kit

MODEL APK-10

Kit includes: One 10 foot steel chain and attaching bracket